



Simplicity
A U S T R A L I A

OPERATORS MANUAL

304 Series

TERRITORY





Contents

Section 1: Introduction

Welcome to Simplicity Australia Company Profile	Page 1.1 1.2
---	-----------------

Section 2: Safety

Safety Instructions – ‘Key Words’	Page 2.1
Location of Safety Decals – LHS and Rear	2.2
Location of Safety Decals – RHS and Front	2.3
Road and Field Travel	2.4

Section 3: Operation

Territory Unit Torque Settings	Page 3.1
Torque Flow Chart	3.2
Hooking up	3.3
Hydraulic Block Operation	3.4
Territory Unit Bleeding Process	3.5
Accumulator Pressure	3.6
Territory Depth Control	3.7
Operating Territory & Hydraulic System	3.8
Territory Depth Control	3.9
Operating Territory & Hydraulic System	3.10
Depth Stop Adjustment	3.11
Territory Infield Setup	3.12

Section 4: Maintenance

Lubrication and Maintenance	
Daily Checklist	Page 4.1
Pre and Post Season Maintenance	4.2
Lubrication and Maintenance Schedule	4.3
Grease Points	4.4
Territory Maintenance	4.5
Tyre Pressure	4.6
	4.7

Section 5: Miscellaneous

Useful Formulae	
Risk Assessment	Page 5.1
Notes	5.2
Disclaimer	5.3
	Rear cover



Welcome to Simplicity Australia

The Management and Staff of Simplicity Australia would like to thank you and congratulate you on your decision to purchase a new Simplicity *Territory* planter.

The design of your Simplicity *Territory* incorporates many innovative features to make your farming operations easier, more efficient, and as the name suggests, simpler.

Your Simplicity *Territory* has been designed and manufactured with the utmost care and pride. By following the operation instructions outlined in this Operator's Manual you will have many years of trouble free operation.

This Operator's Instruction Manual has been prepared to familiarise you with the set up, operation and maintenance of your new Simplicity *Territory*. By reading this Operator's Instruction Manual thoroughly, the most efficient and trouble free operation of your Simplicity *Territory* will be achieved.

Simplicity Australia operates Australia wide through a professional agricultural equipment Dealer network which includes factory trained Sales and Service personnel. If you have any concerns with the operation and maintenance of your Simplicity *Territory* your local selling Dealer will be able to assist you with advice, service and spare parts back up.

Your Simplicity Australia Dealer will register your Simplicity *Territory* for warranty according to the guidelines of the Simplicity Australia Warranty Policy document included in your warranty registration booklet. Please ensure you complete the warranty registration documents in conjunction with your Dealer when you first use your Simplicity *Territory*. Your Dealer will then forward the necessary documentation to Simplicity Australia. Without the relevant documents your Simplicity *Territory* cannot be registered for warranty.

When ordering replacement parts for your Simplicity *Territory* be sure to quote the serial number attached to the machine which is also recorded on the warranty registration certificate.

The Management and Staff of Simplicity Australia sincerely wish you every success with your new Simplicity *Territory* and are available to assist your Simplicity Australia Dealer should they require any specialist assistance.

Yours faithfully

David W. Law
Managing Director

Company Profile

Simplicity Australia Pty Ltd designs and manufactures the most comprehensive and innovative range of Air Seeders and Tillage Equipment in Australia today.

Simplicity Australia has its origins as a small business in Dalby Queensland that started manufacturing Air Seeders in 1979, utilising an auger type metering system.

David Law, owner and Director of Simplicity Australia, saw the potential and bought the Business in 1982. He soon began using Napier distributors for metering seed and fertiliser.

By 1985 he developed and introduced his own innovative metering system to meet the diversity of Australian farming needs. He has continued to develop Air Seeder and Tillage equipment technology using the latest manufacturing methods and expertise to meet changing farmer's requirements while continually increasing product strength, quality, functionality and diversity. All of this has seen customer needs becoming standard features.

With the town of Dalby located in the centre of eastern Australia the Company easily distributes its products through a vast Dealer network Australia wide and internationally.

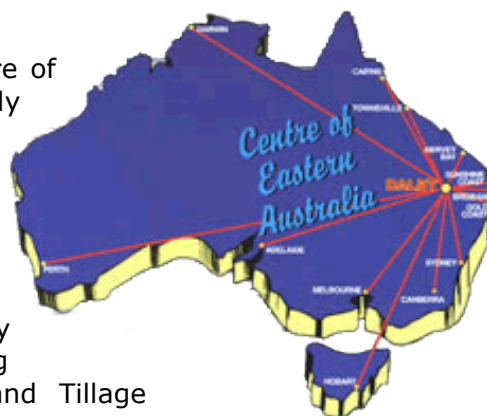

Product strength, quality, reliability and an extensive professional Dealer network providing customised service are key elements of the Company's success in winning its share of the Australian Air Seeder and Tillage equipment market.

Simplicity Australia products have a high degree of customer satisfaction and loyalty with recent research indicating that in excess of 95% of owners will purchase the Simplicity product again.

Today the Company's range of Air Seeders includes seven types comprising over forty different models including liquid options. To compliment Australia's Favourite Air Seeder range, Simplicity Australia also offers the *Territory* planter, *SD-400* disc planter, *Allrounder* cultivator, the *Striker* planting unit and the innovative *X-Bar*.

With all models of Air Seeder and Tillage equipment now manufactured with the latest manufacturing methods and technology combined with a widespread, diverse and professional Dealer network, Simplicity Australia stands ready to maintain and increase its market share in Australia and meet any new challenges future farming requirements may provide.

Safety Instructions

All equipment manufactured by Simplicity Australia has been designed to provide long term trouble free operation with the personal safety of the Operator and others the number one priority.

The equipment can only be manufactured as safe as the person operating it. With this in mind it is very important that the information contained in this Operator's Instruction Manual is read and understood.

It is equally important that this Operator's Manual remains with the equipment to ensure that the Operator has all operating and safety instructions at hand.

Owners of Simplicity Australia product are encouraged to adopt a regular lubrication and maintenance program to ensure long and trouble free operation. This program should also include the maintenance of all safety and accident prevention devices fitted to the equipment as outlined in this Operator's Instruction Manual.

Throughout this Operator's Manual, and on the Planter itself, there are a number of 'safety alert' symbols. Each symbol appears as a white triangle with a red border. Each triangle contains a black pictogram depicting the hazard relevant to that area of the Planter. Any 'safety alert' symbol appearing as an exclamation mark in a red triangle will be a separate decal with associated text.

Two 'Signal' words **WARNING** and **CAUTION** are used in conjunction with the 'safety alert' symbol.

WARNING – indicates a potentially hazardous situation that could result in **DEATH** or **SERIOUS INJURY** if not avoided.

CAUTION – indicates a potentially hazardous situation that could result in **MINOR INJURY** if not avoided.

A master decal itemising each symbol with it's individual pictogram and description is located on the Planter. A copy of the master decal also appears on **Page 2.2 & 2.3** of this Operator's Manual.

This 'IMPORTANT' box identifies procedures that, if not strictly observed, could result in damage to the equipment or other property.

At the time of delivery your authorised Simplicity Australia Dealer will request you sign a 'Safety Declaration' document. Prior to signing this document it is to your advantage to have the Dealer explain the safety features of the equipment to you. This 'Safety Declaration' document is very important and is part of the warranty registration process. Without this document being completed the registration of your Simplicity Australia product for warranty cannot proceed.

The following pages show the Safety Decals and where they are located. For the safety of the operator and others ensure that any safety decal that is damaged or unreadable is replaced.

If further information is required contact your local authorised Simplicity Australia Dealer for assistance.



The symbol identifies points of interest that could result in the more efficient operation of the equipment



Instruct all operators in safe and efficient operation

IMPORTANT

All references to the left side and right side are from the rear, facing direction of travel

Location of Safety Decals LHS and Rear



It is your responsibility to read, and follow safe operating practices defined in the Operators Manual shipped with this unit. Failure to do so may result in Personal Injury to you or others. Manual must remain with machine. If the Manual is missing, obtain a replacement from your dealer.



WARNING: Do NOT disconnect breakaway hydraulic couplings or any other hydraulic connection while hydraulic system is under pressure. Disconnecting hydraulic components while under pressure will result in uncontrollable discharge of hydraulic fluid which may cause injury.



WARNING: HOT - DO NOT TOUCH. Hydraulic components become very hot during normal operation. Contact with skin can cause severe burns.



WARNING: In field and road travel should not exceed 20kph.



WARNING: Do NOT enter underneath seeder at any time unless the machine is secured, stationary, tractor is not running, and hydraulics are closed or have been disconnected.



WARNING: Never allow others to ride on the equipment. Falling from the equipment while in motion can cause death or injury.



WARNING: Be aware of the equipment height when working around overhead power lines. Contact with overhead powerlines will cause serious injury or death.



WARNING: Ensure hitch pin is locked in position and if applicable that the jack is locked in transport position prior to movement.



WARNING: Do NOT check for hydraulic oil leaks with bare hands. Small, almost invisible, high pressure oil leaks can penetrate the skin requiring medical attention.



WARNING: A "Crush Zone" is developed in this area when connecting the implements. Keep bystanders clear of this area when reversing.



WARNING: Rolling Hazard. Ensure wheels are securely blocked before unhooking.



WARNING: Do NOT open bin lids while blower is operating. Release of lids under pressure will cause unwanted movement of seed or fertilizer which could result in injury.



CAUTION: Crush points. Keep hands well clear when moving, calibrating or working.

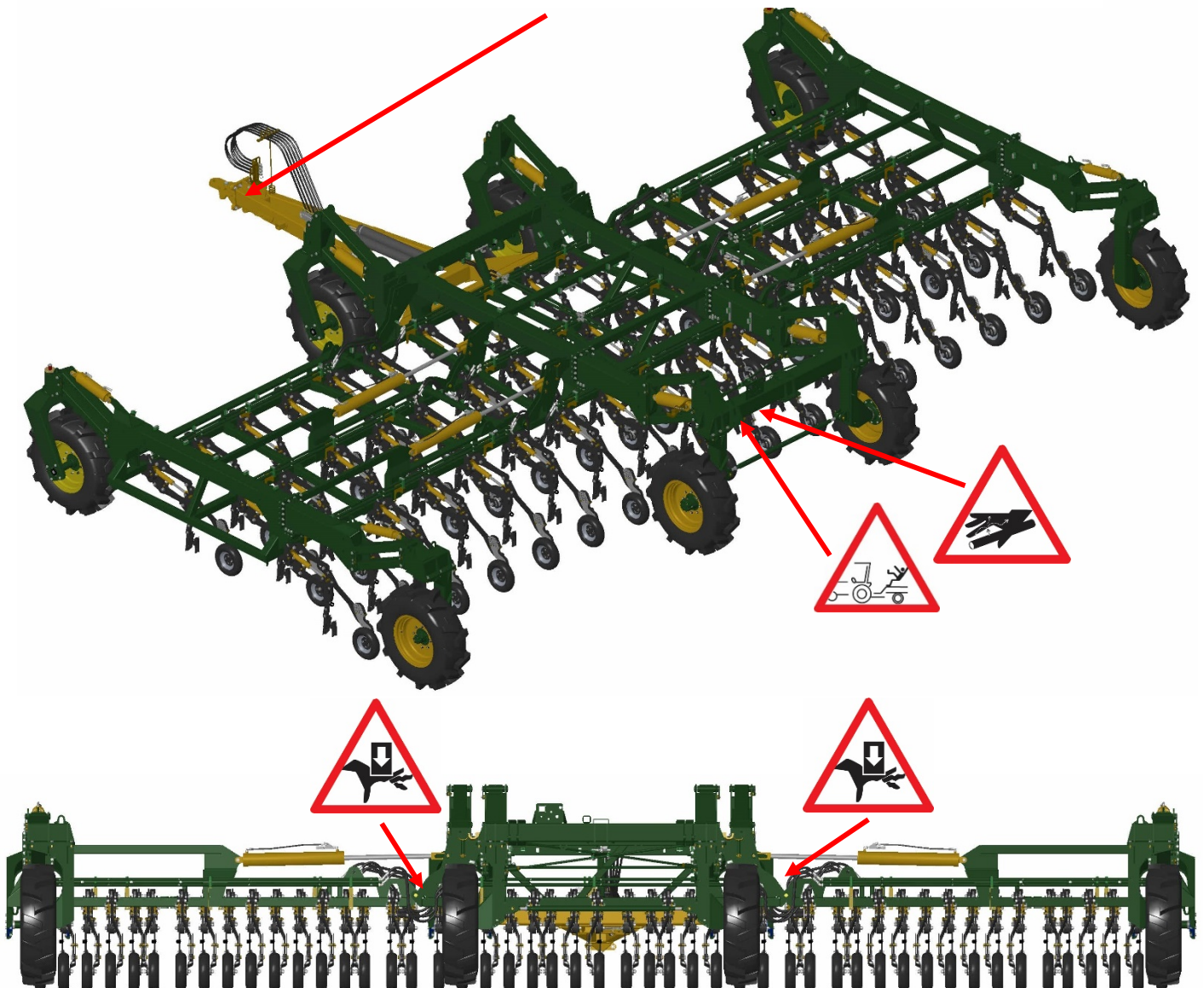

Road and Field Travel

The *Simplicity Territory* is designed with the purpose of **in field** seed planting in mind and therefore is not designed for continuous, high speed, road travel.

However, it is understood that the locations of some working areas would necessitate that the *Simplicity Territory* be moved on public roads from time to time for the purpose of carrying out planting operations.

The *Simplicity Territory* has been designed with this in mind and is quite capable of infrequent, short distance movements on the road providing the following criteria are met:

- ⚠ Always use an agricultural tractor large enough and with sufficient braking capacity to stop the combined unit quickly and safely.
- ⚠ Make sure all wheel nuts on the *Simplicity Territory* are present and tight.
- ⚠ Make sure all hitching components are in good order with all pins secure and there is no possibility of the *Simplicity Territory* coming unhooked.
- ⚠ Make sure jack is in the transport position.
- ⚠ Traveling speed in field or on the road should not exceed 15 kilometres per hour.
- ⚠ Know the equipments' limitations when negotiating changes in road or operating conditions. Reduce tractor speed further over uneven or rough ground and be aware of potential hazards such as bridges, trees, fences, gates, water courses and other road users etc.
- ⚠ Exercise Caution when transporting the *Simplicity Territory* on public roads when wet.
- ⚠ Exercise Caution when transporting the *Simplicity Territory* on public roads in poor visibility.
- ⚠ The dimensions of the equipment may exceed local laws regarding road travel. Always check with the relevant local authority regarding excess dimension requirements before transporting the *Simplicity Territory*.
- ⚠ Be aware of the height of the *Simplicity Territory* when traveling or working around over head power lines.
- ⚠ Do not allow others to ride on the *Simplicity Territory* or any part of the equipment either in field or on the road.
- ⚠ Make certain there is no possibility of any component falling from the *Simplicity Territory*.

IMPORTANT

It is important to remember that the *Simplicity Territory* is **NOT** designed for frequent, high speed, activities and as such Simplicity Australia does **NOT** recommend on road travel other than necessary, infrequent, short distance road travel at a greatly reduced speed following all criteria outlined above.

Territory Unit Torque Settings

3.1.1 Parts Identification

The Territory Unit Pressure Plates are the only part that needs to be altered to achieve the correct operation of the Units. The Pressure Plate Nuts (M20) are the only part that are adjusted to achieve the correct applied force to the Pressure Plates. (See Figure 1.01) The Torque Indicator Tool shown Below will assist in achieving accurate settings. If the Torque Indicator Tool is unavailable (see Figure 1.03)

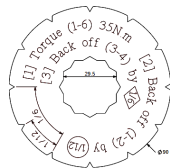

Torque Indicator Tool Part# 970000410

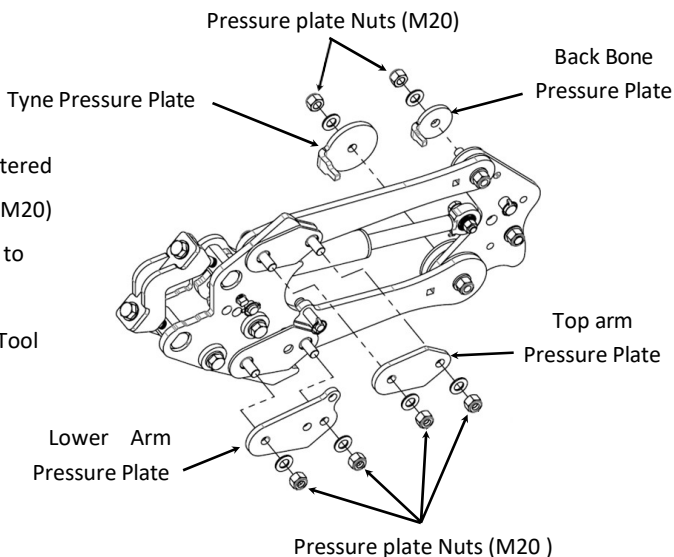



Fig. 1.01 (Pressure Plate & Nuts)

3.1.2 Torque Procedure

The Pressure Plate Nuts receive a specific torque. Overtightening them will prevent the unit from travelling up and down freely and consistently. Follow the process below. **Warning: Only Adjust Nuts 1 to 6 as indicated in (Figure1.02) Altering any other nuts on the Territory Unit can cause Unit Failure.**

1. Loosen all 6 x Pressure Plate Nuts (M20) Half a Turn. (See Figure 1.02)
2. Torque all 6 x Pressure Plate Nuts (M20) to **35Nm** in order of **1 to 6**. (See Figure 1.02)
3. **Loosen Nuts 1 and 2, (1/12 of a turn)**  (see Figure 1.03) Or use Tool 970000410
4. **Loosen Nuts 3 and 4, (1/6 of a turn)**  (see Figure 1.03) Or use Tool 970000410

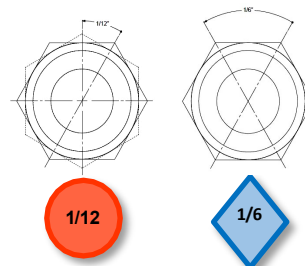

Fig. 1.03 (M20 Nut Castellations indicator)

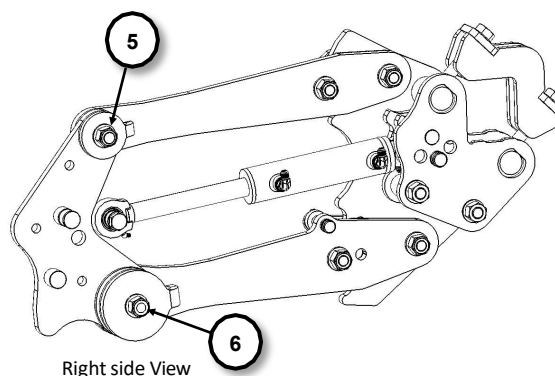
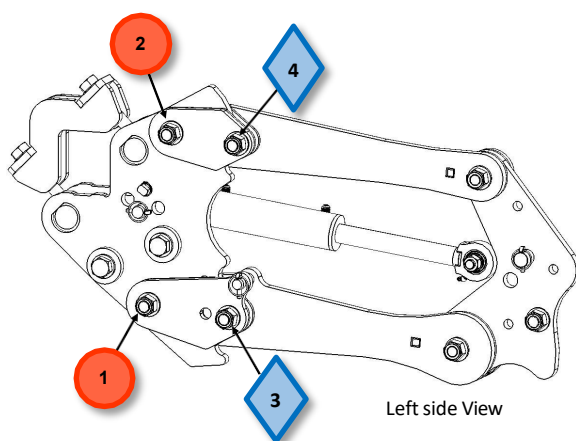
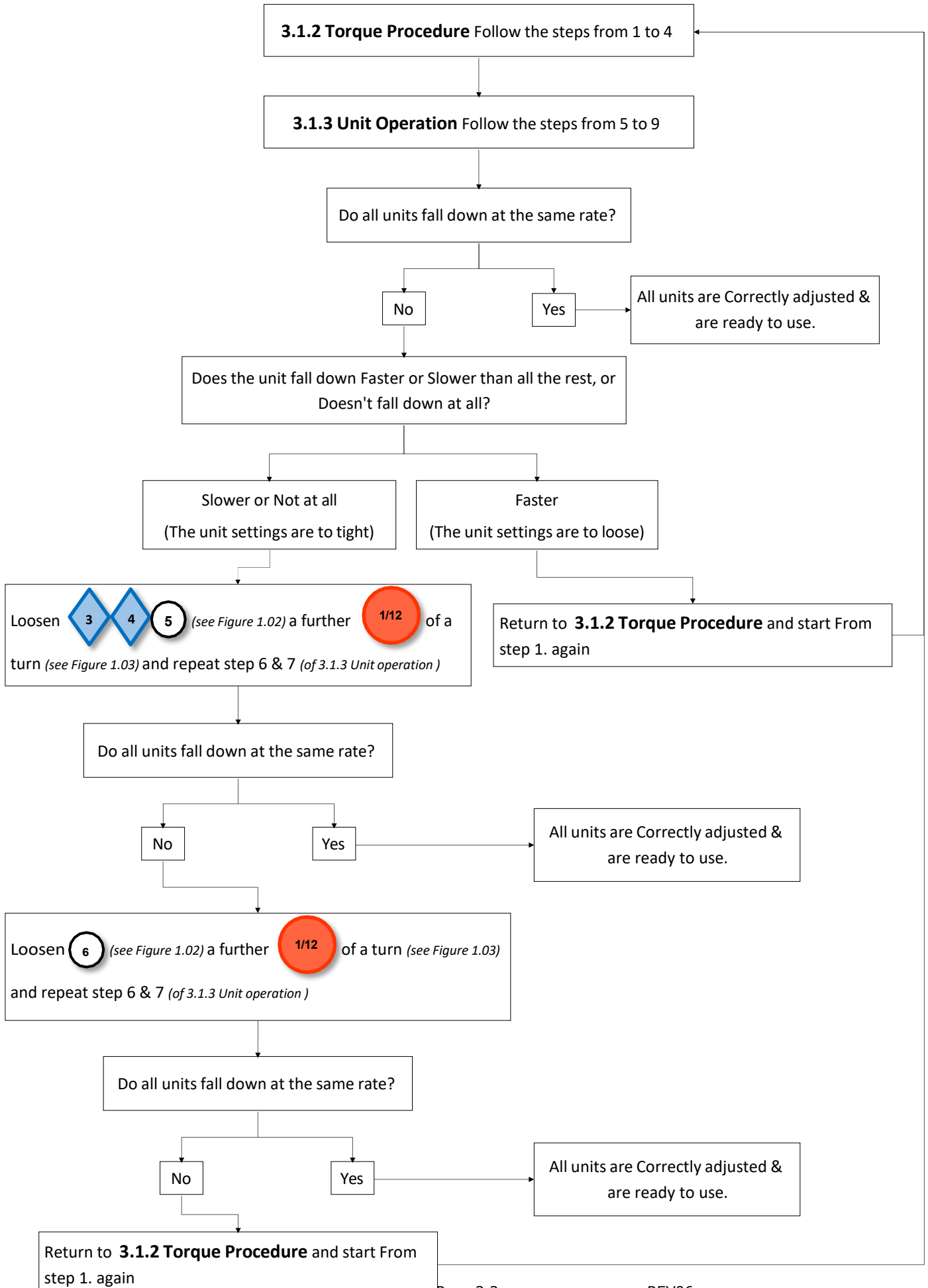

Fig. 1.02 (Pressure Plate Nuts M20)

3.1.3 Unit Operation

5. Start the Tractor.
6. Place the Tyne Circuit Switch into the ON position (the switch should illuminate) — Lift all the Units up.
7. Place the Tyne Circuit Tractor Remote into Float — Allow the units to fall down under their own weight.
8. Do all units Fall at the same Rate. Yes or No? (repeat step 6 & 7 if needed)
9. If No, continue to the Flow chart (3.1.4 Torque Flow chart) and follow the steps. If Yes, all units are set correctly and are ready to use.

3.1.4 Torque Flow Chart



Hooking Up

The Simplicity *Territory* is manufactured to suit specific customer requirements for a wide range of farming applications. As Simplicity Australia has no control over the make and model of the tractor or Air Seeder the Planter is to be used with, it is necessary to ensure you have the correct components required for the hitching process with the given machines.



WARNING: A 'crush zone' is developed in this area when connecting the implement to the tractor. Keep bystanders clear of this area when reversing



When hitching planter to tractor drawbar use the largest pin possible.

Crush points, impact and entrapment risks are hazards which are produced by the relative movement of one machine to the other when hooking up. The safety of the Operator and any assistant is of highest priority. Be aware of the hazards that hooking together machines can produce.

Be sure to:

- Connect all hydraulic lines making sure all hose ends are perfectly clean prior to connection
 - **RED:** Tyne and Accumulator
 - **YELLOW:** Fold
 - **BLUE:** Lift
- Connect electrical wiring harnesses
- Once Connected ensure jack is raised, and moved to the Transport Position.
- Ensure hitch pin is correct size for both tractor and cultivator. (Use as large a pin as possible).

Steerable Tongue (Non-Steer Models)

Ensure that the pivot pin retaining bolt is secure.

Check that the pivot locking bolt is secure.

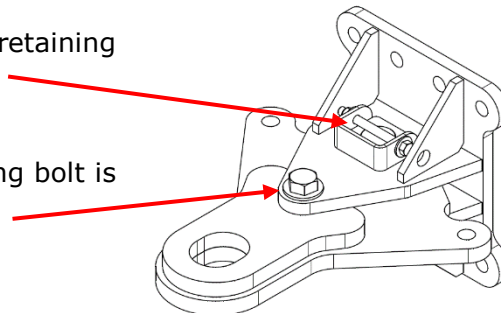

Hydraulic Block Operation

Your Simplicity Territory planter is fitted with a hydraulic block to filter and control the planting unit hydraulics.

This hydraulic block controls accumulator pressure and tyne lift and lower circuit.

The Frame Lift circuit is just a filtered bypass through the main hydraulic block.

The wing fold circuit does not operate through the main hydraulic block.

The tyne circuit and accumulator pressure both operate from the same tractor remote.

There is an electrically operated poppet cartridge on the retract side of the tyne circuit. In the normally unpowered state, the poppet holds tyne pressure this valve is closed, holding tyne pressure in.

When switched on, the valve opens the return circuit back to tractor.

Both of the accumulators are connected to the retract side of the tyne circuit.

Hydraulic Control Block

Lift Circuit

Your Territory uses a phasing circuit on the rams that lift and lower the main frame. When operating correctly, all rams move identically, raising and lowering the frame in an even and level manner. Occasionally it is possible for air to seep in, or oil to seep out of this system, causing the functionality to be impaired. When this occurs it will be necessary to re-phase the circuit. Each ram has a small pilot valve that opens when fully extended, allowing a small amount of flow to the next cylinder in the circuit.

Re-Phasing

When re-phasing the lift circuit it is recommended to reduce hydraulic flow and pressure.

1. Check to ensure all depths stops are open prior to re-phasing.
2. Lift the frame all the way to the top of travel.
3. Continue to hold lift for a further 10 seconds and watch for all cylinders to stroke out fully.
4. Lower the frame all the way to the bottom of travel.
5. Lift the frame all the way to the top of travel.
6. Continue to hold lift for a further 5 seconds and watch for all cylinders to stroke out fully.
7. Lower the frame to check for even and level movement.
Repeat if necessary.

Territory Unit Bleeding Process

One of the benefits of any hydraulic system, is that the inherent stiffness leads to instant and accurate response. It is of chief concern to make certain that there is no elasticity within the hydraulic system.

Air in a hydraulic system can make the response spongy, as air is compressible and creates a delayed response. It can also allow cavitation that can destroy hydraulic components.

The objective of bleeding the hydraulic system is to release any pockets of air which may remain in the system. To effectively bleed the hydraulic system all tyne cylinders must be completely cycled several times to extract pockets of trapped air.

1. Lift the Machine, Unpin the unit and check all units are in the down position.

2. Attach the bleed taps to both upper and lower bleed connections on one end of the bar.

3. Switch the Tyne circuit to " LOW FLOW " and switch Tyne Pressure "ON"

4. Open the Bottom Tap and start pressurizing the system to lifting the unit up. (Oil and Air will be forced out of the bottom circuit by lifting the units up.) Once you see the units in the up position close the Bottom Tap and stop pressurizing the system.

5. Open the Top Tap and start pressurizing the system to lowering Unit down (Oil and Air will be forced out of the Top circuit by lowering the units down.) Once you see the units in the down position close the Top Tap and stop pressurizing the system.

6. Repeat Step 4 and 5 until all the air is removed from one side of the machine.

7. Place the Tyne Circuit Hydraulics into float, let the system depressurizing and remove the bleed taps. Place the Bleed Taps on the opposite end of the bar and repeat steps 4 and 5. Continue bleeding both ends of the machine until all the air is removed from the system.

8. Once all air is removed from the system, check and see if all the unit are operation together. If the units are all operation together then no further bleeding is required. If not continue bleeding the air until all units are operating together

Note: When bleeding the circuit, pay attention to the hydraulic oil reservoir level. It is recommended to catch oil in clean containers in order to re-fill the reservoir.



DANGER		Tyne Circuit Bleed Ports	
	HIGH PRESSURE FLUID HAZARD	↑ Lift Units	
	<ul style="list-style-type: none">• Relieve pressure on hydraulic system before servicing or disconnecting hoses.• Wear proper hand and eye protection when searching for leaks.• Keep all components in good repair.	↓ Lower Units	

Accumulator Pressures

The accumulator is a storage area of controlled pressurised oil to maintain an appropriate pressure in the tyne circuit during the fluctuations of loads to the hydraulic system. Adjusting this pressure in turn controls the necessary break-out force for the tines

IMPORTANT

Accumulator will not work as desired if the gas pressure inside accumulator is higher than the accumulated pressure.

Accumulators



The accumulators themselves consist of a piston with pressurised Nitrogen gas on one side and a volume of oil on the other. As the volume of oil increases, the resisting force from the gas being compressed; pressurises the hydraulic lines.

To Set The Accumulator Pressure

1. Activate tyne switch on the switch box.
2. Activate remote and observe pressure reading on accumulator pressure gauge.
3. Once it reaches desired pressure, switch ACCUMULATOR switch OFF.
4. Place hydraulics into float.



Accumulator Pressure Gauge

The pressure relief valve is set to 950 psi. When accumulator pressure exceeds 950 psi, oil will flow back through accumulator circuit.

To adjust accumulator pressure:

1. Set hydraulics from float to neutral.
2. Turn ACCUMULATOR switch ON.
3. Adjust tyne pressure up or down as required.
4. Turn OFF ACCUMULATOR switch.
5. Return hydraulics to float.

ALWAYS LEAVE TYNE CIRCUIT IN FLOAT.

For operations where it is necessary to quickly reduce accumulator pressure (for example when working over shallow rock), simply turn **on** ACCUMULATOR switch. Provided remote is already in float (normal operating position) this will allow accumulator pressure to drop rapidly. When clear of obstacle, adjust tyne pressure back to normal, De-activate Tyne Switch, and return hydraulics back to float.



It is important to ALWAYS set the SCV control to FLOAT, and ACCUMULATOR switch is OFF for all in field operation.

Territory Depth Control

- The Range of depth control range on the Territory is 120mm, depending on tyne style and conditions this allows a max seed depth of roughly 120mm in 6mm increments
- All depth holes are identified alphabetically from "A" to "U".
- "A" shallowest option
- "U" deepest option

To change depth

1. Raise bar so units hang and clear the ground
2. Remove lynch pin from locking pin
3. Identify which letter hole you would like to select
4. While holding handle on back side of the press wheel slide locking pin out
5. Using the handle lift or lower the press wheel to your new hole aligns with the slot in the press wheel arm and re-insert locking pin
6. Confirm pin location is correctly through press wheel arm slot and replace lynch pin

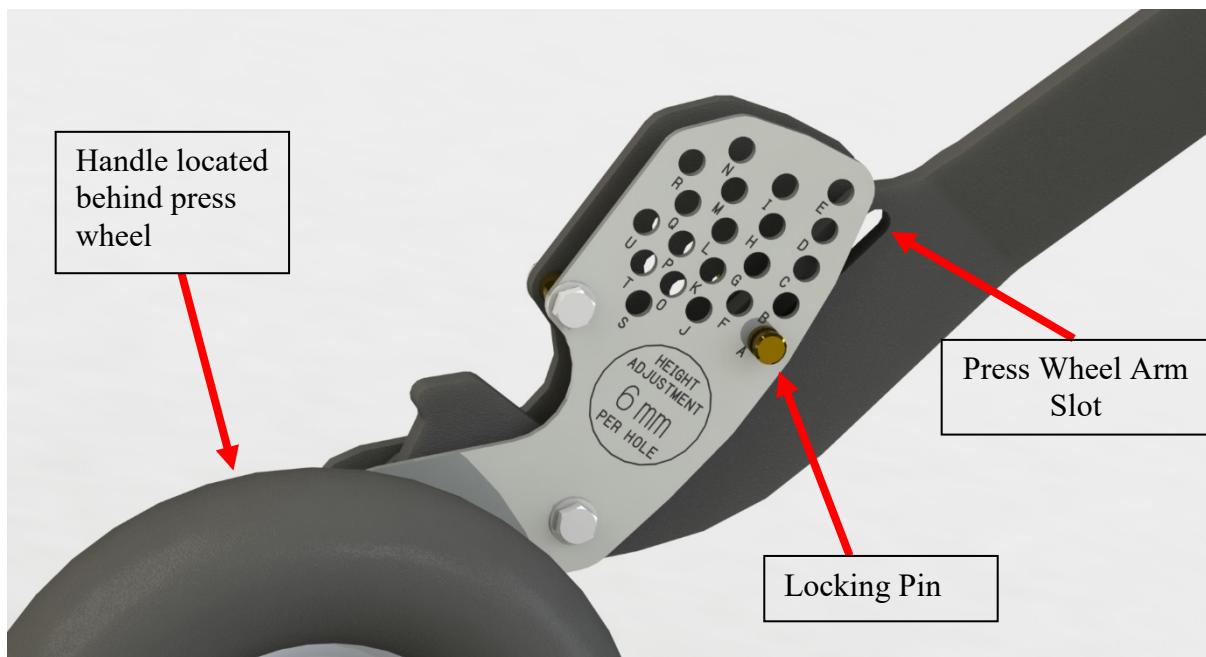

Operating Territory & Hydraulic System

- The Territory unit uses an accumulated hydraulic system not requiring a constant flow from your tractor simply set your desired system pressure Switch Power Off & float you remote
- A double acting hydraulic ram is fitted to allow the units to be fully retracted and pinned up this function operates best with the "Heavy" press wheel down force option selected
- Any hydraulic operation requires the check valve to be energised with 12 volts to allow oil to pass in our out of the accumulator system
- A relief valve is fitted to prevent over pressurization of the system and damage to the units during operation, for this to work it is important to Switch Power off to float the tyne circuit remote after pressure has been set and "TYNE" switch has been turned off

Lifting units

1. Select "TYNE Switch" on switch Box
2. Using your dedicated tyne hydraulic circuit "RED" Lift until all units have fully raised

Note: Lifting of the units operates best when "HEAVY" down force is selected

3. Units can now be locked up by pinning in position with two pins

Pin "A" – holds the unit from falling down
Pin "B" – holds the tyne in the break out position

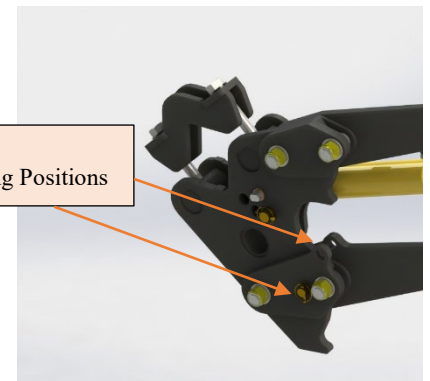
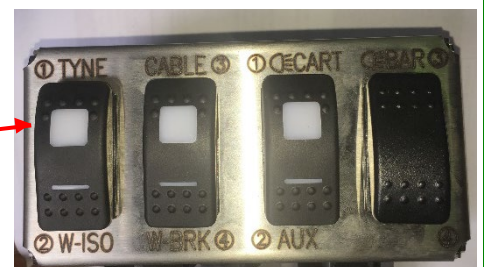

Pin "A"
Storage & Locking Positions

Lowering units and charging Accumulator

4. One Pined float remote, depressurize system
5. De-activate Tyne Switch

Pin "B"
Storage & Locking Positions

1. Remove Lock up pins if fitted
2. Select "TYNE" on switch Box
3. Using your dedicated tyne hydraulic circuit "RED" lower units until all tynes have kicked forward
4. Continue operating Hyd remote until desired pressure in accumulators has been reached. Max 1050Psi
5. Return "TYNE" switch to off (middle position)
6. Place remote in Float

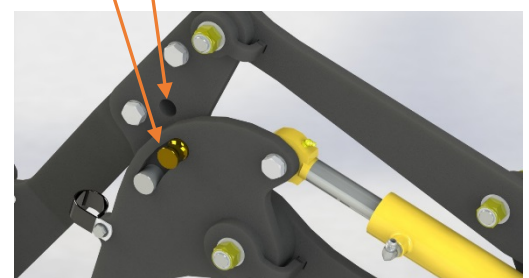

Depth Stop Adjustment

IMPORTANT

Prior to any hydraulic operation make certain area is free from obstructions, and be sure there are no people in the immediate vicinity of equipment.



WARNING: Failure to follow these guidelines can result in damage to your frame and componentry

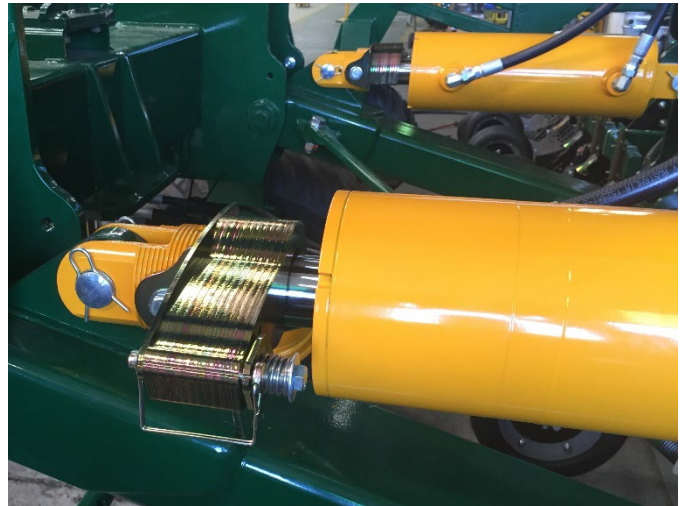

The operation of the depth stop system is very easy, simply remove the lynch pin select number of shims required and reinsert the lynch pin. This controls the depth of the entire bar by controlling the stroke of the master cylinders in the phasing hydraulic system of the lift cylinders. Below is a couple of critical rules to adhere to when any depth stops are fitted

- Ensure both master cylinders are set evenly
- Shims must always be selected starting from the clevis end



Always start from clevis end

IMPORTANT

WARNING

MINIMUM 3 SHIMS



INTERNAL SEAL DAMAGE MAY OCCUR
(Please refer to Operators Manual)



Tyre Breakout & Press Wheel Down Force

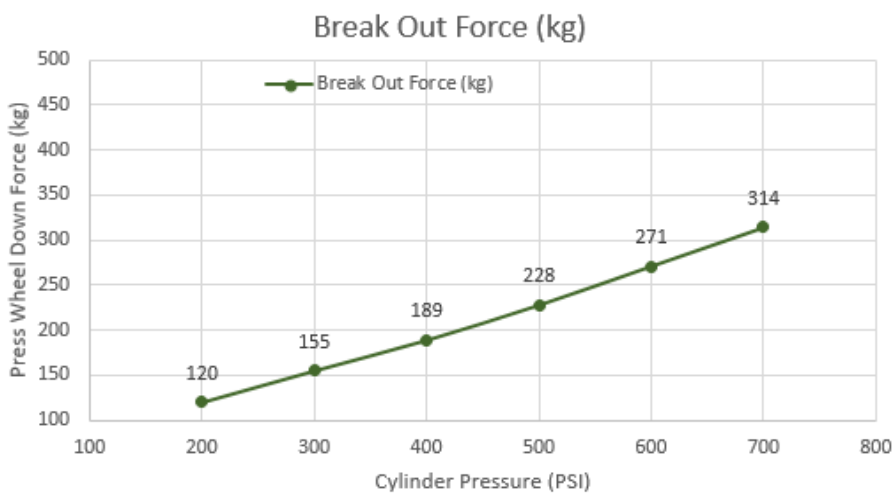
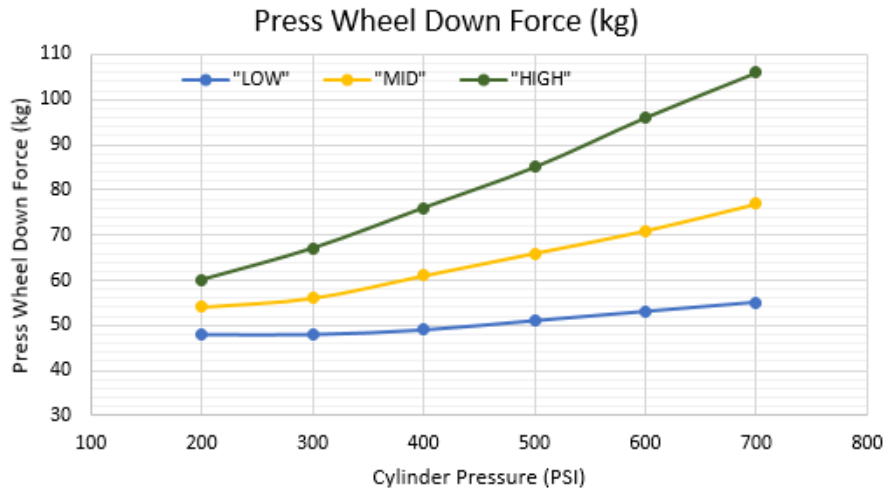

Territory Opener - Static B/O (kg)				
Cylinder Pressure (PSI)	Break Out Force (kg)	Press Wheel Down Force (kg)		
		"LOW"	"MID"	"HIGH"
200	120	48	54	60
300	155	48	56	67
400	189	49	61	76
500	228	51	66	85
600	271	53	71	96
700	314	55	77	106

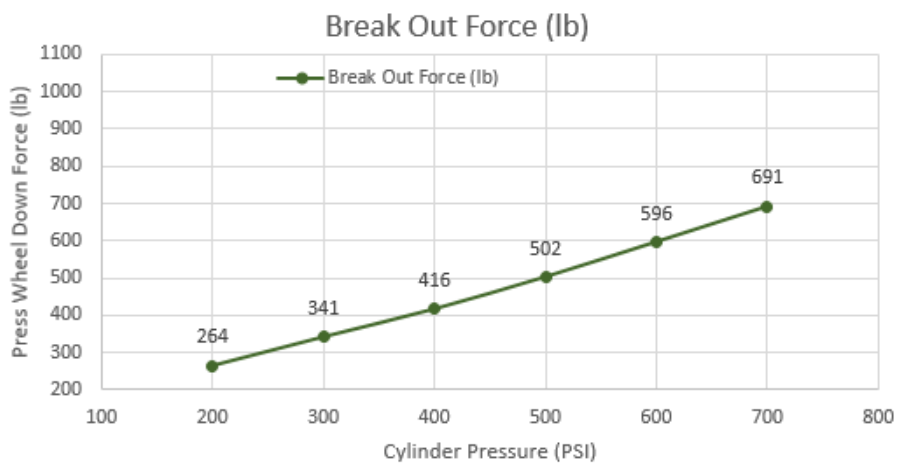
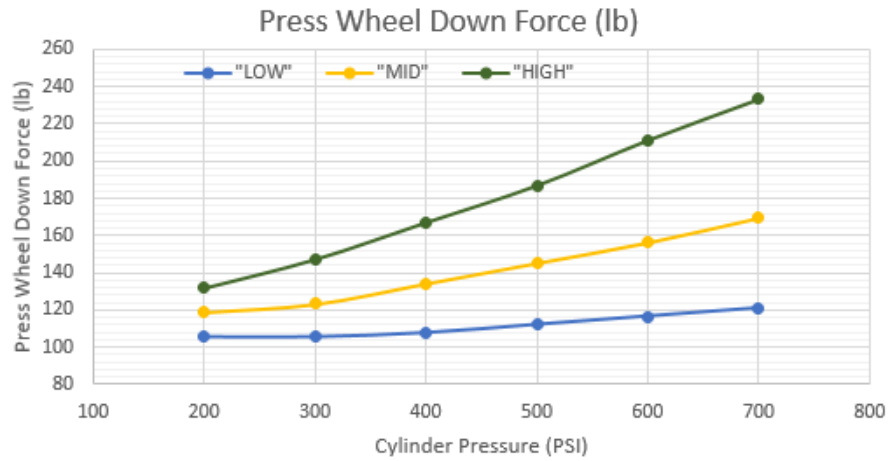

Territory Opener - Static B/O (lb)				
Cylinder Pressure (PSI)	Break Out Force (lb)	Press Wheel Down Force (lb)		
		"LOW"	"MID"	"HIGH"
200	264	105.6	118.8	132
300	341	105.6	123.2	147.4
400	416	107.8	134.2	167.2
500	502	112.2	145.2	187
600	596	116.6	156.2	211.2
700	691	121	169.4	233.2

Territory Infield Setup

Carry out these steps to find the correct Accumulation pressure needed.

1. Seeding Depth: Use The Tine Press Wheel depth adjustment to set the depth you want to sow.
2. Set all the Cylinder adjuster pin into the **light down force position**. (as per the photo provided) Put the Accumulation pressure on **Zero** (use the operators manual to correctly operate the Accumulation pressure, which you have indicated is being used correctly)
3. Enter the field and lower the Bar so that the unit parallel arms are roughly parallel with the ground (As per Photo) and set the depth stops.
4. Start driving to planting speed, turn the tine switch on and slowly increase the accumulation pressure just enough so that the tines are in the ground, but are still able to breakout through or over objects. **Do not start with a high pressure and go down, you need to start at zero and work your way up.** (The Accumulation pressure might end up be lower than you think you need) Once correct pressure is found, turn tine switch off and place hydraulic remote into float.
5. Now stop and check that you have the right amount of compaction from the press wheel. (if you need more compaction, move the cylinder adjustment pin from the light position to the Medium position) **Do not just increase the accumulation pressure, this has already been set to the field conditions in the previous step.**



Note: The setup may need to be repeated if the field conditions change.

6. Once all steps have been carried out, start sowing. When getting to the end of the row, lift the bar out of the ground and then drop it back in, there is no need to touch the already set and isolated tine circuit.

Lubrication and Maintenance

Owners of Simplicity Australia product are encouraged to adopt a regular lubrication and maintenance program.

By following the Pre Season, Daily, Weekly and Post Season lubrication and maintenance programs outlined in this Operators Manual and in conjunction with your preferred Simplicity Australia Dealer, long and trouble free operation is achievable.

Pre Season

Before sowing, at the beginning of the season, it is important that the pre season procedures outlined in the Schedule **Page 4.4** are checked off, and prior to use ensure all checks listed on **Page 4.3** have been completed. Following the procedures outlined in these check lists should ensure a trouble free season.

Contact your Simplicity Australia Dealer for a Pre-Season check of all equipment.

Daily Checks

The 'Daily Checklist' **Page 4.2** should be used in conjunction with the daily procedures outlined in the Schedule **Page 4.4** to ensure trouble free daily operation of the Simplicity "Allrounder".

Weekly Checks

The weekly checks outlined in the Schedule **Page 4.4** are procedures which can, but don't need to be, carried out every day. It is advisable that once a week during a period of use, *further* to the daily checks, these additional checks also be completed.

As outlined in the Lubrication and Maintenance Schedule **Page 4.4** the majority of the lubrication program is required to be carried out on a weekly basis. Following this weekly program is essential in achieving the maximum service life from all components of the Simplicity "Allrounder".

Post Season

Following the 'Post Season Maintenance' checklist **Page 4.3** in conjunction with the 'Post Season' procedures outlined in the Schedule **Page 4.4** prior to storage will ensure that minimal component deterioration occurs and that the cultivator is ready for trouble free operation next season.



Proper care, regular maintenance and lubrication will ensure years of trouble free operation and product life

IMPORTANT

Over greasing can shorten the service life of some components

IMPORTANT

The necessary Tyne lubrication period is entirely dependant upon application. Where the operation results in a great deal of movement in tyne pivot points more frequent greasing may be necessary. (i.e. When being used for primary tillage, or when tynes are regularly being broken out)



After some time (depending on amount of use) it is advisable to unpack the wheel bearing grease hubs and repack with fresh grease.

Daily Checklist

Check:

- Periodically check wheel nut tension throughout the first days after delivery until wheel nut tension is maintained
 - Hydraulic lines are correctly coupled at all breakaway connections, and system is free from leaks
 - Ram seals for leaks
 - Cylinders are in phase
 - Oil flow is reduced when unfolding and folding
 - Accumulator valve control solenoid functioning correctly
 - Condition of tines
 - That all stands, guards and safety pins are in correct position for operation
 - Air Seeding system (Seeding Kit) free from blockages and leaks (if attached)
 - Correct Tyre inflation
-



Time taken to carry out Daily Checks should ensure daily trouble free operation

Pre Season Maintenance

Maintenance should be carried out on a regular basis depending on frequency of use.

Ensure:

- All nuts and bolts are tight
- Check tyre pressure – Adjust if necessary (as per page 4.2)
- Tyres in good condition
- Grease wheel bearings and check preload
- **All** pins are secure and are not worn
- Hydraulic hoses are not cracked or perished
- All greaseable joints have been adequately lubricated (as per page 4.5)
- Welded joints have not fatigued
- Lift cylinders are phased correctly
- Hydraulic circuit has been bled and is free from air locks
- Adequate hydraulic oil in tractor Reservoir
- Tine shanks and sweeps are in good condition
- Air Seeding system free from blockages and not cracked or perished

Post Season Maintenance

- ⚠ Ensure no hydraulic circuit is stored with pressure in its system. Breakaways should be disconnected with tractor hydraulic system in float. This will ensure circuits are filled with oil at minimal pressure.

Check:

- All hydraulic components are in good condition, free from leaks, and functioning correctly
- Wheel bearings are packed with grease and have smooth movement (*free from damage*)
- Tyres are in good condition with an acceptable tread depth
- Cultivator is generally clean (*no buildup of material which may retain moisture and cause damage*)
- A suitable rust preventative is sprayed on any area where the powder coat has been damaged or worn away, and bare metal is exposed.
- Contact your Simplicity Australia Dealer and place an order for any service parts or wear and tear item such as tyne shanks, points etc.



To maintain the appearance of the powder coat finish used in production it will be necessary to wash the exterior of the *Territory* with water and a soft cloth.

IMPORTANT

Do not use high water pressure, abrasive materials or harsh cleaning products as irreversible scratching could occur

IMPORTANT

Do not use steam or hot water as a cleaning medium. Some hydraulic components such as hydraulic rams depend on the oil residue left on them as a rust barrier

Lubrication and Maintenance Schedule

<p style="color: red; text-align: center;">Use in conjunction with pages 4.2 & 4.3</p>	Adjust wheel nut tension																	
	Check wheel bearing preload																	
	Grease wheel bearings																	
	Hydraulic control block & hydraulic lines are free from leaks																	
	Check fold pins are in place and bolts are tight																	
	Hitch pins in place & secure																	
	Hydraulic lines are securely connected																	
	Pull pivot pins are in place and bolt is tight																	
	Check hydraulic pins are secure with end clips in place																	
	All safety decals are clearly readable and in position																	
	Tyre Rams are free from damage and/or leaks																	
	Tyre pressures																	
	Grease pull pivot pins																	
	Grease fold ram rollers																	
Grease Ram cylinder pins																		
Grease wheel support arm pivot pin																		
As per "Post Season Maintenance"																		
Periodically during 1 st season use	X																	
After first ten hours		X	X	X														
Daily				X	X	X	X	X	X	X	X							
Weekly												X	X	X			X	
Pre Season	X	X	X	X	X	X	X	X	X	X	X	X	X	X	X	X	X	
Season End																	X	

Grease Points

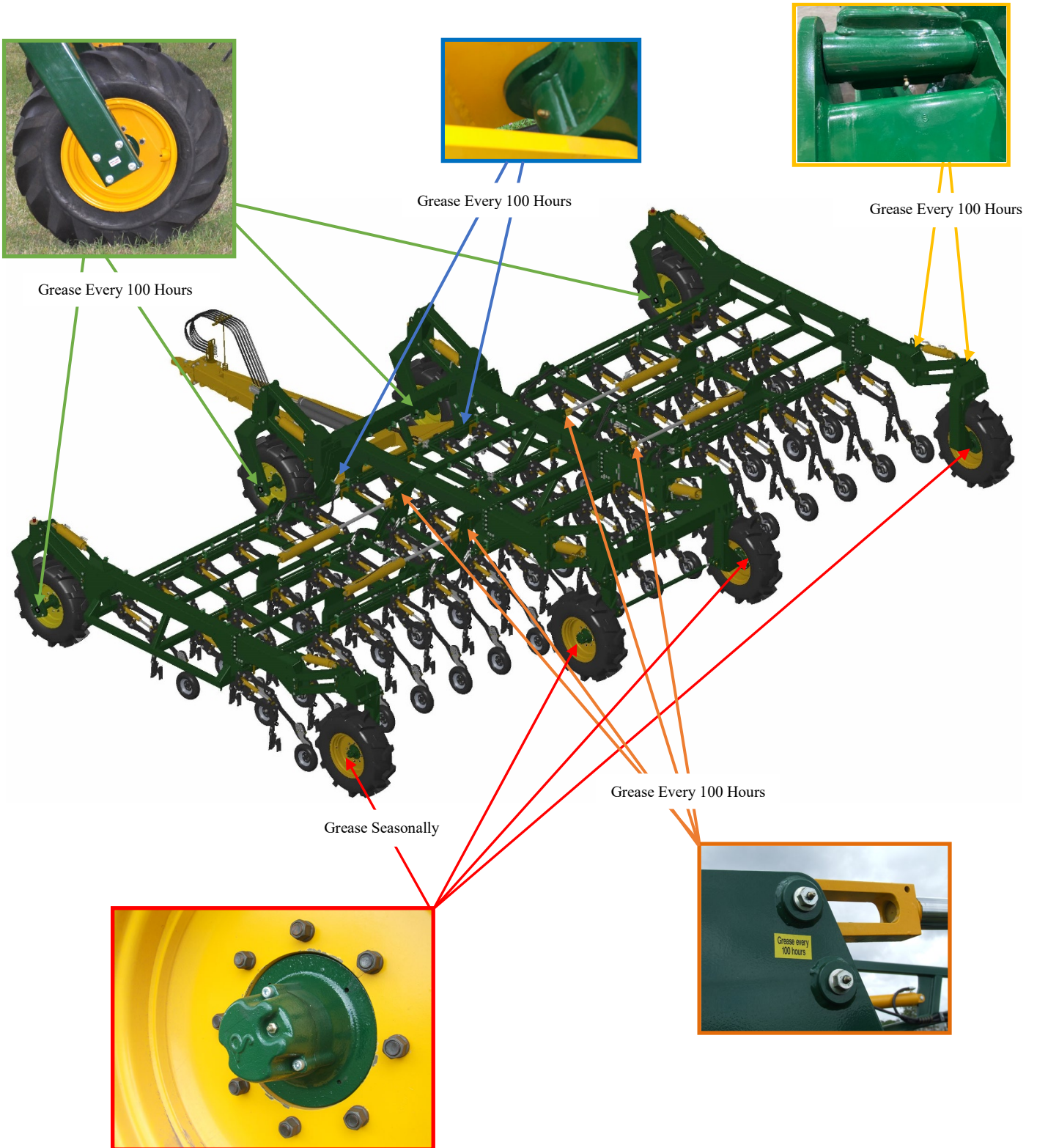

Territory Maintenance

- Check head stock clamp bolts tension (350Nm) after **first 12Hrs then seasonally**
Note: when using supplied special access adaptor set TORQUE @ 262Nm
- Grease cylinder every **50 Hrs**
Note: units must be in raised position for access to both grease nipples

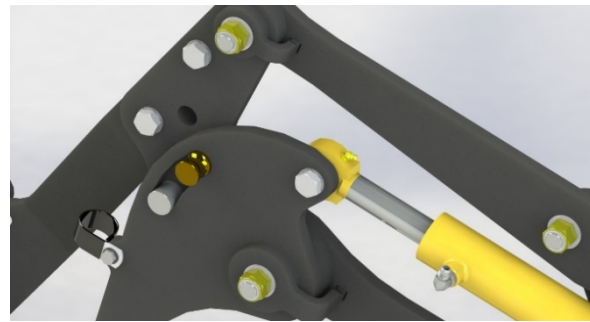
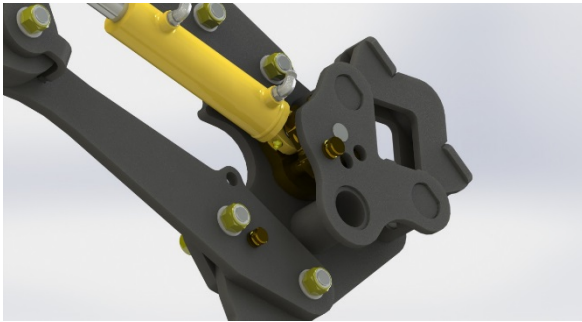

- Check tension on bearing pads every **250 Hrs**
- **Tighten all nuts as per sequence on drawing.** 

Note: M20 Retaining nuts receive a specific torque. Overtightening them will prevent the unit from travelling up and down freely and consistently. Follow process below.

1. Tension in order of numbers on drawing with settings listed below.
2. Loosen required nut by 1/12th or 1/6th of a turn as indicated in the Torque settings.

Torque Settings

1. 35Nm then loosen 1/12 of a turn
2. 35Nm then loosen 1/12 of a turn
3. 35Nm
4. 35Nm
5. 35Nm then loosen 1/6 of a turn
6. 35Nm then loosen 1/6 of a turn

Note: 1/12 of a turn is half a castellation of the nut and 1/6 of a turn is one castellation of the nut.

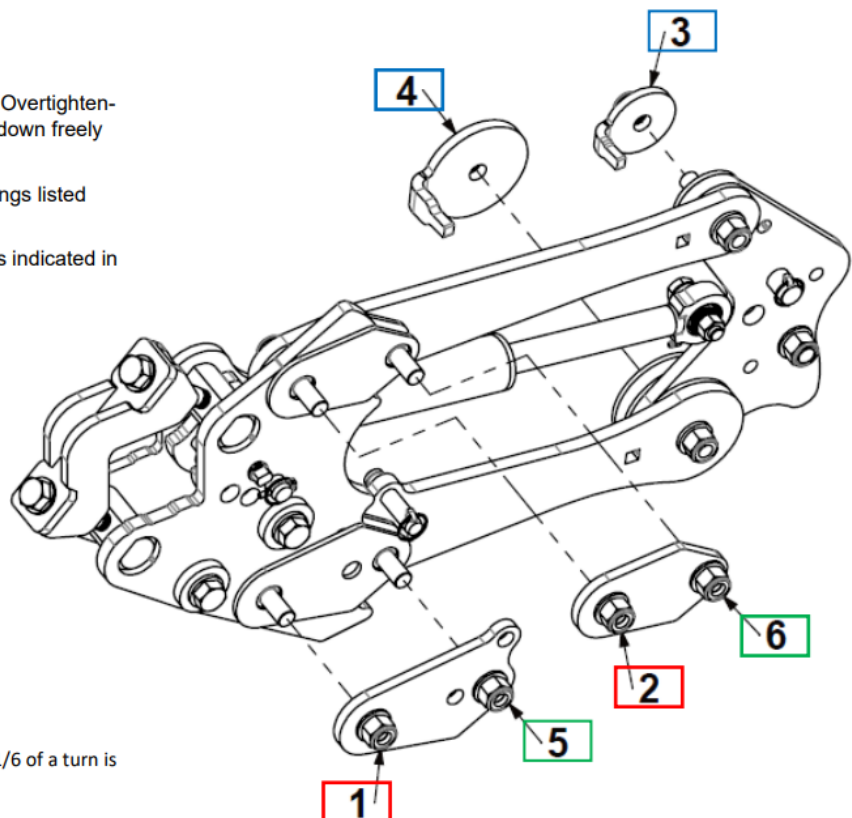

Tyre Pressure

Tyre Inflation:

When setting tyre pressures many variables come into play, such as; weight vs. transport weight, min/max speed, working conditions, aftermarket additions. Being each machine varies in many of these areas it is impossible if list an exact tyre pressure for each machine. Therefore below is a list of recommended tyre pressures which will suit most applications.

 *The centre section tyres must be set when the machine is folded and on hard ground to determine correct tyre pressure for transport

Tyre Pressures For 304 Series (3 Section)			
Machine	304		
Sections	3 Section		
	Min	Max	
Machine Width (m)	8	12	anything outside range (Contact Simplicity)
Row Spacing (mm)	250	375	
Tooling (kg/unit)	0	4.5	



Centre Frame Wheels - Front

Tyre - 15.5/80 x 24 - 16 Ply 163A6**
 Rec. Inflation* = 44 PSI
 Max Inflation = 58 PSI

Wing Wheels - Front (Left & Right)

Tyre - 15.5/80 x 24 - 16 Ply 163A6**
 Rec. Inflation* = 36 PSI
 Max Inflation = 58 PSI

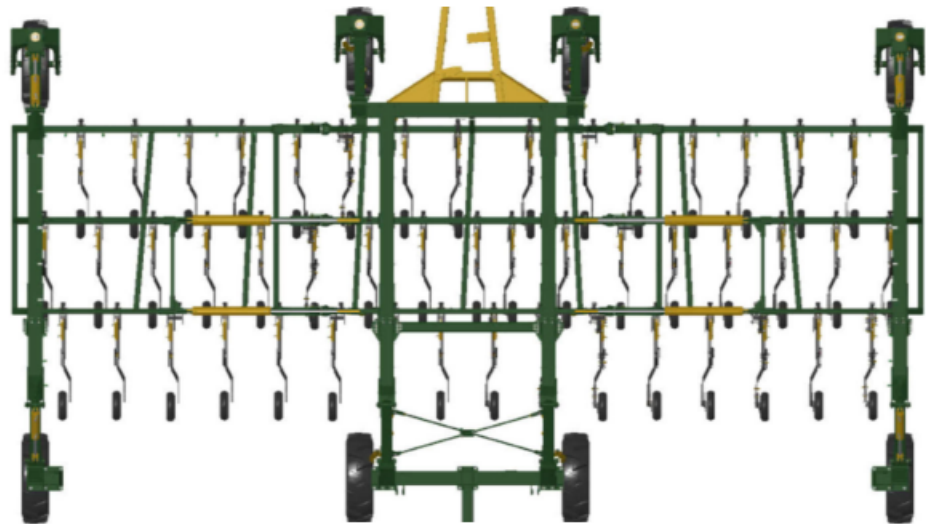

Centre Frame Wheels - Rear

Tyre - 15.5/80 x 24 - 16 Ply 163A6**
 Rec. Inflation* = 44 PSI
 Max Inflation = 58 PSI

Wing Wheels - Rear (Left & Right)

Tyre - 15.5/80 x 24 - 16 Ply 163A6**
 Rec. Inflation* = 36 PSI
 Max Inflation = 58 PSI

Index

Rec = Recommended

Recommended Torque Settings

M18 Wheel Studs: 253 ft.lbs (344N.m)

Reference Notes

*An Increase to Recommended Tyre Pressures may be required to level machine,

Do Not Exceed Max Inflation Pressure.

**Load Index is for Free Rolling Tyre's

All Inflation Pressures are @ 25km/h

Wheel Nut Tension

M18 stud 27mm Nut
 250 lbf ft/340Nm



CAUTION: Specialist Repair. Tyre Repair or replacement should be carried out by suitably trained personnel using the correct equipment.

IMPORTANT

Failure to maintain tyre pressures within range of those listed may result in damage to the tyre as well as decreasing the life of the tyre.

Useful Formulae/Conversions

Length

1 km =	0.62 mile	1 mile =	1.609 km
1 m =	3.28 ft	1 ft =	0.304 m
1 mm =	0.039 inch	1 inch =	25.40
mm			

Area

1 ha =	10,000 m ²	=	2.47 acre	
1 acre =	4840 sq. yd	=	0.40 ha	
1 km ² =	0.38 sq. mile			1 sq. mile = 2.589
km ²				

Volume

1 m ³ =	35.31 cu.ft			1 cu.ft = 0.028 m ³
1 litre =	.22 gal.			1 gal = 4.54 litre
1 litre =	0.26 US gal			1 US gal = 3.78 litre
1 bushel =	8.00 gal	=	1.28 ft ³	
1 litre =	0.027 bushel			1 Bushel = 36.36
litre				

Pressure

1 psi =	6.89 kPa			1 kPa = 0.14 psi
1 Bar =	14.5 psi			

Mass

1 kg =	2.20 lb			1 lb = 0.45 kg
1 kg =	1000 grams			

Application Rate

1 kg/ha =	0.89 lb/acre			1 lb/acre = 1.12
kg/ha				

Mass Flow Rate

$$\text{kg/hr} = \text{Application Rate (kg/ha)} \times \text{Area Rate (ha/hr)}$$

$$\text{kg/min} = \frac{\text{Application Rate (kg/ha)} \times \text{Area Rate (ha/hr)}}{60}$$

$$\text{lb/hr} = \text{Application Rate (lb/acre)} \times \text{Area Rate (acre/hour)}$$

$$\text{lb/min} = \frac{\text{Application Rate (lb/acre)} \times \text{Area Rate (acre/hour)}}{60}$$

**Risk Assessment
Hazard Checklist for *Territory***

Product Description	Simplicity Territory		
Model		Serial Number	
Date of Inspection		Location of Inspection	
Inspected by:		Signature	

Hazard	Risk Source	Safety Measure	Safety Measure Check?
Incorrect Operation	<ul style="list-style-type: none"> Lack of Information 	<ul style="list-style-type: none"> Comprehensive Operator's Manual with safety and operating information 	Yes
Crushing	<ul style="list-style-type: none"> Wings Falling When in Transport Position Hitch Dropping 	<ul style="list-style-type: none"> Counter Balance Valves Fitted Hydraulic Jack Fitted Warning decals fitted at all crush points 	Yes Yes Yes
Falling off during operation	<ul style="list-style-type: none"> Riding on Cultivator during operation 	<ul style="list-style-type: none"> Warning Decals Fitted 	Yes
Contact with over head power lines	<ul style="list-style-type: none"> Transport Height 	<ul style="list-style-type: none"> Warning decal fitted 	Yes
High pressure fluid leak	<ul style="list-style-type: none"> Hydraulic hoses 	<ul style="list-style-type: none"> Hoses clamped at close intervals to prevent rubbing 	Yes
Oil ingress through skin	<ul style="list-style-type: none"> Checking for hydraulic leaks with hands 	<ul style="list-style-type: none"> Warning decal fitted 	Yes



Simplicity Australia Pty Ltd
18 Loudoun Road
P.O. Box 267
Dalby QLD 4405
Australia
www.simplicityaus.com.au

2014

Disclaimer: We reserve the right to alter the design or discontinue any of the Company's products or services without notice. Whilst every effort has been made to ensure the accuracy of the information contained in this publication, our Company Policy of continual research and product development necessitates changes and refinements which may not be reflected in these pages. If in doubt, please contact your **nearest Simplicity Australia Dealer**